

**interlift**  
LYFT- & MATERIALHANTERING



**Eltelfer LIFTKET**

LYFTDON | TELFRAR | TRAVERSER | KRANAR | VINSCHAR | LYFTBORD | LYFTVAGNAR | PLÅTHANTERING

- » High duty rate
- » Patented safety-brake-clutch system
- » Modular hoist design
- » Simply and cost effective maintenance and repair
- » Different chain qualities available
- » Quick and safe change between single and double fall of chain
- » Low voltage control with changeable components – no printed circuit boards

Kapacitet (kg)	Parter	Lyfthastighet 50 Hz (m/min)	STAR Modell	Lastkätting (mm)	ISO / FEM	ED (%)	Starter / timme (S/h)	Effekt lyftmotor 50 Hz (kW)	Egenvikt vid 3m lyft (kg)	A (mm)	B (mm)	C (mm)	G (mm)	G2 (mm)	J (mm)	Typ av balkvagn (kg)	F Balkbredd (mm)	Åkshastighet 50 Hz (m/min)	Effekt åkmotor 50 Hz (kW)				
125	1	8/2	031/53	5.2x15	M7/4m	60/40	360	0.32/0.08	18	212	192	220	380	406	20	EFW 500	N50-106	5/20	0.04/0.18				
250*	1	8/2	031/51		M6/3m	50/25	300		18				18	380	406					20			
500	2	4/1							21				407	454	22								
500*	1	8/2	071/54	7.2x21	M5/2m	60/25	240	0.9/0.2	42	266	232	274	413	460	22	EFW 2000	N66-135	5/20	0.04/0.18				
1000	2	4/1							47				514	561	28								
1000*	1	6/1.5	071/55						1.1/0.2				42	413	460					22			
2000	2	3/0.75											47	514	561					28			
1600	1	8/2	091/55						9x27				3.0/0.75	88	513					548	28	EFW 3200	N82-155
3200	2	4/1												97	359					283	359		

\*finns även med direktstyr manöverdon, i övrigt gäller lågvolt (24v)

### Krok/plåtupphängd

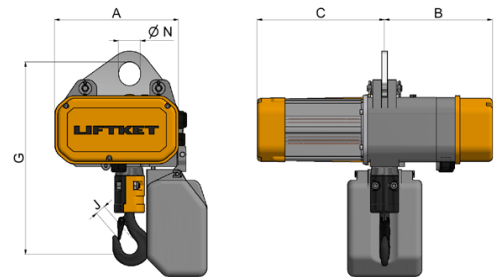

### Driven/manuell blockvagn

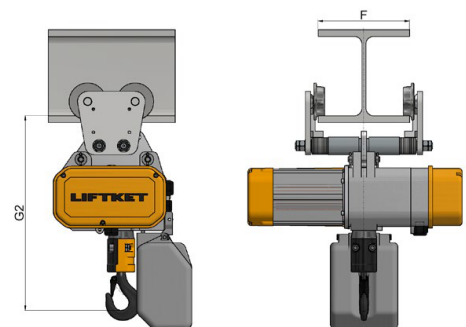

### Technical data:

- Power supply 400 V, 3 ph, 50 Hz
- Different voltage and frequency options available on request
- Protection class IP55
- Insulation class F
- 1.5 m standard control cable
- 3 m standard lifting height
- Different lifting height and control cable lengths available on request
- For lifting heights of more than 20 m the safe working load will be reduced by the chain weight
- STAR models 090/..., 091/..., 110/... and 111/... have to be equipped with a low voltage control





# LIFTKET

## INDUSTRY

LIFTKET electric-chain hoists are used in almost every sector of industry. Whether it's for a stonemason or the food industry, shipyards or power stations – we lift and move weights in a safe, precise and reliable way.

The LIFTKET product portfolio offers you standardized hoists that can be adjusted to your requirements in a modular way, as well as highly specialized solutions. Larger lifting and operating heights are just as viable as deviating voltages and special solutions of any kind.

You tell us what you want to move – and we will develop and supply the perfect solution.

### FEATURES

From 80 kg to 25,000 kg we lift everything that moves you • FEM ratings from Fem 1Bm to 4m (ISO M3 to M7) • Protection class IP55, insulation class F • Galvanised load chain to DIN 818-7 quality class DAT • A wide range of options can be selected as standard • Optional one or two lifting speeds from 2 to 32 m/min • With heavy-duty end position switch-off as standard (at 24VAC)

### STATIONARY VERSION

- Stationary version with hook or eye
- Eye (connection between crane and trolley) compatible with all commercially available trolleys and suspensions

### STAR VFD

- Load-dependent, infinitely variable control from 2 to 36 m/min
- Up to 200 % faster without load
- Easy-to-read display with operating hours, remaining service life according to FEM
- Brake cycles and starts

### TROLLEYS // BOGIES

- Manual or electric trolleys in various designs for each steel section girder
- Short suspension and precise horizontally suspended hoist due to two-bolt suspension
- High-quality, galvanized impellers and fall protections



# LIFTKET

## CUSTOM

You need it extra-short? Extra-high? Extra-long? Extra-fast? Extra-customized? Are you looking for single pieces in serial production? Batch size one? Then you've come to the right place at LIFTKET!

Decades of experience, professional ability and our willingness to master any challenge brings our tailor-made applications to life – even when produced in series. You benefit from the best quality and innovative technology. And our own developments and production from a single source render your custom products real.

Your individuality is our reality. Just watch your dreams come to life!



### APPLICATIONS FOR INDIVIDUAL SOLUTIONS

Any application deviating from the standard, e.g. foundry • Power stations • Food industry • Modernisation and conversion of old industrial plants • Pharmaceutical industry • Water treatment

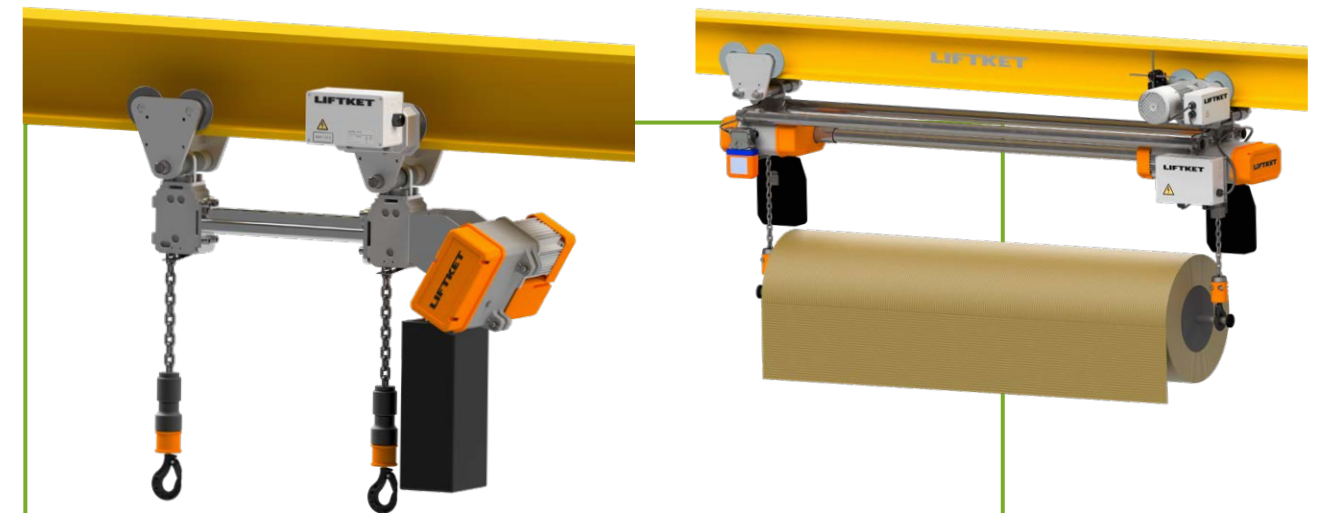

## SPECIAL SOLUTIONS

Selection of flexibly configurable features:

- Lifting height and lifting speeds
- Space heaters
- Special corrosion protection up to C5 in any colour
- All control and operating voltages
- Versions for foundries
- Second hoist brake
- Load measuring equipment
- Extra short chassis
- Trolleys for curved tracks
- Gear-type limit switch with several switching points
- Encoder for positioning and automatic mode

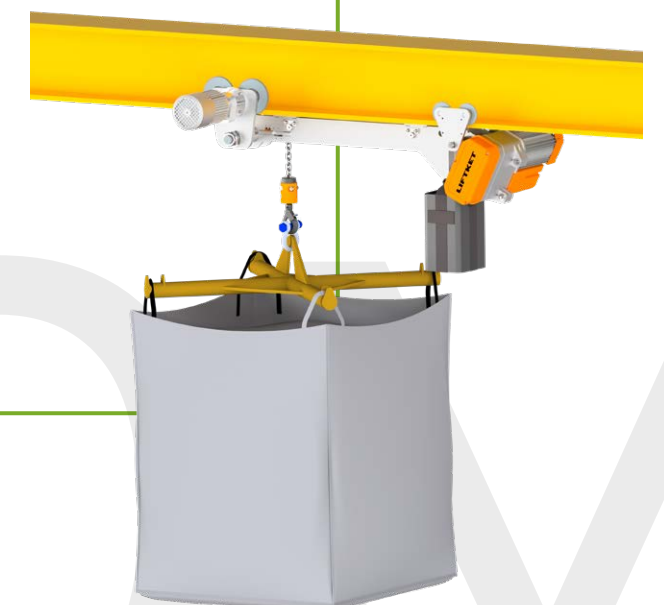
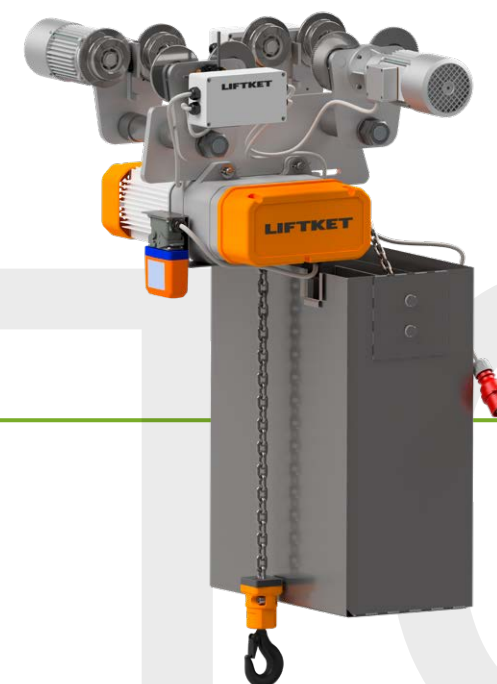

## Interlift AB

Interlift AB har sedan starten 1994 förstärkt och breddat sitt produktsortiment inom lyft- och materialhantering.

Högsta kvalitet och hög säkerhet är viktigt inom all lyftverksamhet och självklart både för oss och våra leverantörer.

Med lång och gedigen erfarenhet i kombination med viljan att alltid vara lätt tillgängliga, är vår fortsatta strävan att vara ditt bästa val.

Vänd dig med förtroende till Interlift – ett starkt val när det gäller lyft- och materialhantering!

### Service och reparationer

Vi utför service, reparationer, registerhållning och besiktning av alla lyftdon, oavsett fabrikat.



Getinggränd 2 · 275 39 Sjöbo · Tel 0416-174 00

Bronsyxegatan 9B · 213 75 Malmö · Tel 040 -22 12 90

**VÅR SAMLADE ERFARENHET INOM LYFT- OCH MATERIALHANTERING STÅR TILL DITT FÖRFOGANDE OCH VI ÄR ALDRIG LÄNGRE BORT ÄN DIN NÄRMSTA TELEFON.**